

SP 系列/高壓支撐缸
SP Series/high pressure supporting cylinder

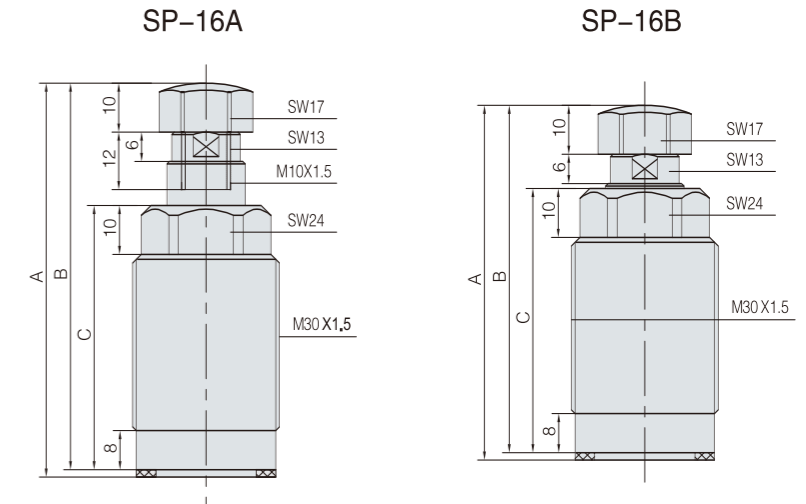

安裝底座示意圖
Schematic diagram of mounting base

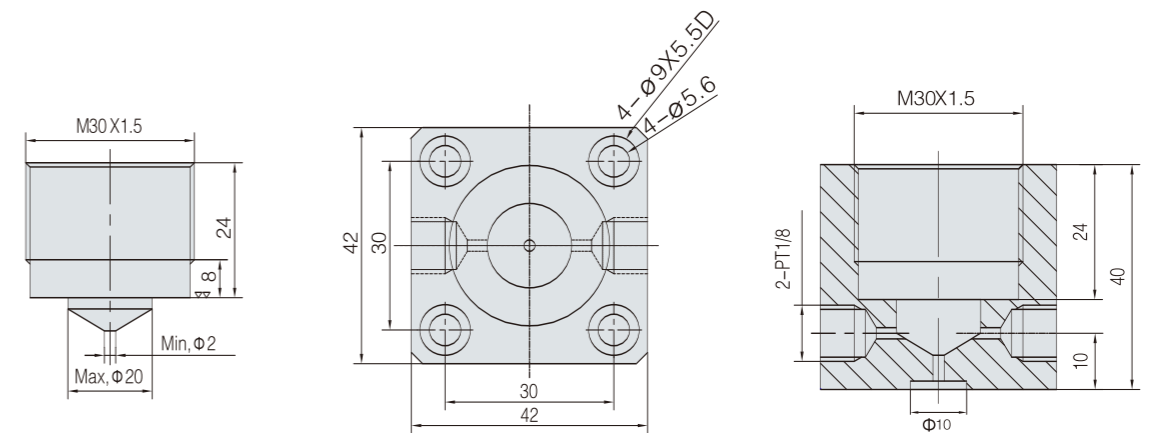

規 格

尺寸 Dimension	Model 型號	SP-16A1	SP-16A2	SP-16B1	SP-16B2
頂杆直徑 Piston diameter mm		Φ16			
頂杆行程 Piston stroke mm		8			
最小操作壓力 Minimum operation pressure		100kg/cm ²			
頂杆接觸工件力量 Contact force		Min=0.8kg Max=1.3kg Min=1kg Max=2.3kg			
理論夾持力500kg/cm ² Theoretical supporting		650kg	950kg	650kg	950kg
A mm		80.5	90.5	72.5	82.5
B mm		79	89	71	81
C mm		54	64	54	64

注：此規格產品還有一種SP-25A或SP-25B，即頂杆直徑為25mm的產品。歡迎垂詢選購。
Note: We have another product SP-25A or SP-25B with piston diameter 25 mm.