

STARKY

TC 螺紋單動缸

TC Thread-body Single Acting Hydraulic Cylinder

TC系列/油壓螺紋單動缸

TC Series/ Hydraulic screw single-acting cylinder

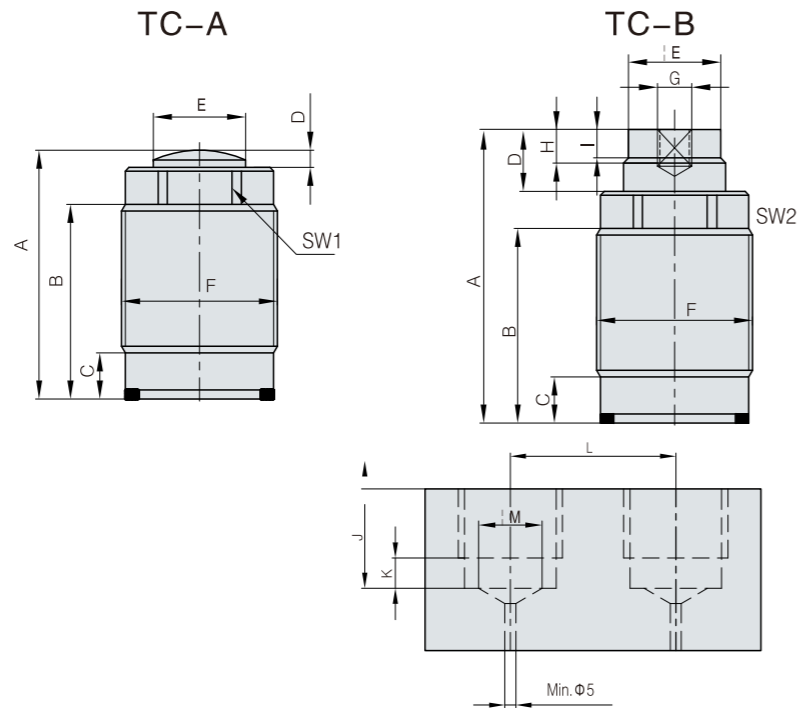

安裝底座示意圖
Schematic diagram of mounting base

規 格

尺寸 Dimension	Model 型號	12A	16A	20A	25A	12B	16B	20B	25B
頂杆直徑 Piston diameter mm		Φ12	Φ16	Φ20	Φ25	Φ12	Φ16	Φ20	Φ25
頂杆行程 Piston stroke mm		10	12	15	16	10	12	15	16
理論夾持力 Theoretical clamping force	500kg/cm ²	110	200	300	490	110	200	300	490
	500kg/cm ²	570	1000	1570	2460	570	1000	1570	2460
彈簧回復力量 Spring return force kg		2.5	5	7	12	2.5	5	7	12
最小操作壓力 Min operation pressure g/cm ²		10	10	10	10	10	10	10	10
需油量 Oil volume cc/10mm		1.13	2.01	3.14	4.91	1.13	2.01	3.14	4.91
A		38.5	47	56.5	60	45.5	53	66	69
B		29.5	34.5	42.5	45	29.5	34.5	42.5	45
C		8.5	9.5	9.5	13	8.5	9.5	9.5	13
D		3	3.5	4	5	10	9.5	13.5	14
ΦE		Φ12	Φ16	Φ20	Φ25	Φ11	Φ15	Φ19	Φ23
F		M22*1.5	M26*1.5	M30*1.5	M38*1.5	M22*1.5	M26*1.5	M30*1.5	M38*1.5
G		—	—	—	—	M6*1.0	M6*1.0	M8*1.25	M8*1.25
H		—	—	—	—	7	7	9	9
I		—	—	—	—	5.5	5.5	6	7
J Min/Max		16.5/25	20.5/33	24.5/42	28.5/44.5	16.5/25	20.5/33	24.5/42	28.5/44.5
K Max		8	9	9	11	8	9	9	11
L Min		25	30	35	43	25	30	35	43
M Min/Max		Φ9/Φ12	Φ12/Φ16	Φ14/Φ20	Φ18/Φ25	Φ9/Φ12	Φ12/Φ16	Φ14/Φ20	Φ18/Φ25
SW1		18	22	26	33	18	22	26	33
SW2		—	—	—	—	10	13	17	19